



Grown...to meet challenges

INSTRUCTION MANUAL

VITAL-T

Compact Vibrating Fork

Version 1.0

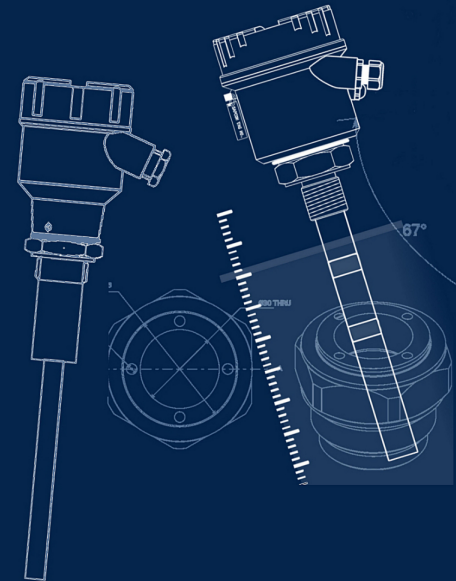
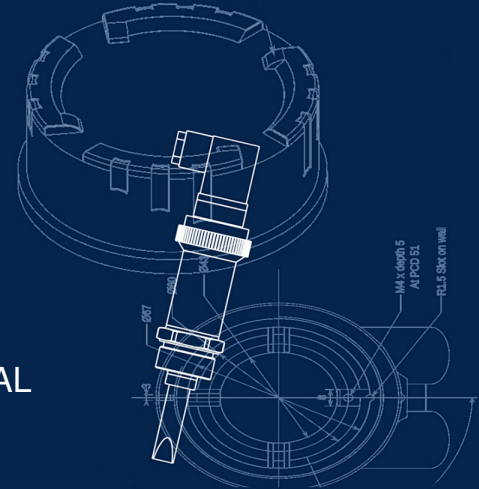

SAPCON INSTRUMENTS PVT. LTD.

30+ Years in Process Control Instrumentation

An ISO 22000 company

www.sapconinstruments.com

Contents

Revision History	4
1 Introduction	5
2 Operating Principle	5
3 Features	5
4 Applications	5
5 Application Specifications	6
6 Electrical Specifications	7
7 Mechanical Specifications	7
8 Installation Guidelines	8
9 Electrical Connections	8
9.1 For Fail-safe High	8
9.2 For Standard Connector	8
9.3 For M-12 Connector	8
9.4 For Fail-safe Low	8
9.5 For Standard Connector	8
9.6 For M-12 Connector	9
10 Output Check Test	9
10.1 Output Indications	9
11 Sensitivity	9
12 Error Indications	10
13 Customer Support	11
14 Order Code	12

List of Figures

1 Vital-T	5
2 Description of Parts	5
3 Vital -T with Baffle	8
4 Cable Gland Arrangement	8
5 Fail-safe High	8
6 M-12 Connector Connection for Fail-safe High	8
7 Fail-safe Low	9
8 M-12 Connector Connections for Fail-safe Low	9

List of Tables

2	Application Specifications	6
3	Electrical Specifications	7
4	Mechanical Specifications	7
5	Sensitivity	9
6	Error Indications	10

Revision History

Revision	Date	Author(s)	Description
1.0	28 Apr 2022	RND	First Version Editing

1

1

- **Copyright:** All content on this document, such as text, graphics, logos and images is the property of Sapcon Instruments Pvt. Ltd. The selection, arrangement and presentation of all materials on this document and the overall design of this document is the exclusive property of Sapcon Instruments Pvt. Ltd.
- The images shown in this manual may differ from the actual instrument / housing in terms of dimensions, color and design. Please refer to GA drawings for dimensional details.
- Values (of performance) described in this manual were obtained under ideal testing conditions. Hence, they may differ under industrial environment and settings.

General Instructions

- Instrument shouldn't block the material filling inlet.
- Secure the cover of housing tightly. Tighten the cable glands. For side mounting, the cable glands should point downwards.
- For side mounting, provide a baffle to prevent the material from falling on the probe.
- When handling forks, do not lift them using their tines. While using them with solids, ensure that material size is less than 10mm.
- Deforming the shape of the tines may interfere with the fork's operating frequency.
- Make all electrical connections as instructed in the manual. Don't power on the device before verifying the connections.

1 Introduction

Vital-T is a vibrating fork level switch for level detection, it is suitable for all kinds of solid which do not react with SS 316 .where the process temperature ranges between 0°C to +150°C .



Figure 1: Vital-T

2 Operating Principle

A specially shaped tuning fork is kept vibrating using piezo-electric elements. The oscillations of the fork dampen when it comes in contact with the application material. The loss of oscillation amplitude is detected and used for switching the output. The output contacts of the relay are in turn used for annunciation and / or control.

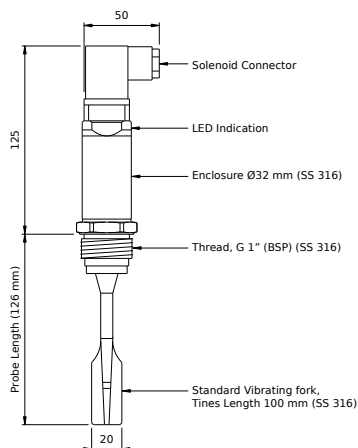

Figure 2: Description of Parts

3 Features

- Power Supply: 18-30 V DC
- Output: Open collector PNP, LED Indication
- Operational temperature: 0°C to 150°C (Fork)
- No calibration required at site, easy to install
- Compact in size

- Service friendly plug-in connection
- Rugged stainless steel housing
- Operational safety ensured
- External circuit testing by test magnet

4 Applications

Vital-T is suitable for all Fast packaging machines for powders the following applications are:

- Sugar
- Detergent
- FMCG
- Red Chilli powder
- Turmeric powder

5 Application Specifications

Please refer to Table 2 for Application Specifications.

PARAMETER	VALUE
Sensitivity	<ul style="list-style-type: none"> • Dense Media/Build Up - 1 • Lighter Media - 5
Density of media (min)	0.7 gm/cm ³
Particular Size	A maximum of 6mm
Response Time with 'NS' option	<ul style="list-style-type: none"> • Cover Delay : 1-2 second • Uncover Delay : 1-3 seconds
Response Time with 'FS' option	<ul style="list-style-type: none"> • Cover Delay : 1-2 second • Uncover Delay : 1-3 seconds
Operating Temperature	<ul style="list-style-type: none"> • Ambient Temperature: 0°C to 60°C • Process Temperature: 0°C to 150°C

Table 2: Application Specifications

6 Electrical Specifications

Please refer to Table 3 for Electrical Specifications.

PARAMETER	VALUE
Input Power Supply	18-30 V DC
Output	Open Collector - PNP Output (Load capacity upto 90 mA at 24 V DC)
Switching Indication	Red /Green LED ON/OFF
Switching Behavior	<ul style="list-style-type: none"> • ON • OFF
Fail-safe Feature	Field selectable <ul style="list-style-type: none"> • Fail-safe High (For Overflow Protection) • Fail-safe Low (For Dry Run Protection)
Power Consumption	Without Load <ul style="list-style-type: none"> • 600 mW @ 24 V DC • 300 mW @ 12 V DC With Load 3W @ 24 V DC

Table 3: Electrical Specifications

7 Mechanical Specifications

Please refer to Table 4 for Mechanical Specifications.

PARAMETER	VALUE
Mounting	Thread Mounting: 1" BSP / NPT / M12
Electrical Connector	Valve Connector, M12
Cable Gland	PG 11 / PG 9
Active Fork Length	100 mm
Probe Length	126 mm
Process Temperature	Up to 150°C
Sensing Fork Material	SS 316
Fork Finish	Standard Fork
Pressure	Up to 10 Bar

Table 4: Mechanical Specifications

8 Installation Guidelines

While installing the instrument, please take care of the following points:

1. The instrument should be installed in horizontal or vertical position only.
2. Observe that when installed directly under the material inlet source, a canopy called baffle of appropriate strength and size should be welded right above the instrument as shown.

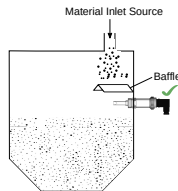

Figure 3: Vital -T with Baffle

3. To prevent the ingress of moisture and water seepage in side mounting position, the cable entries should always point downwards.

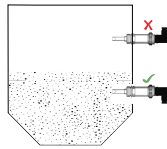

Figure 4: Cable Gland Arrangement

4. Secure the cover of housing tightly. Tighten the cable glands.
5. Make all electrical connections as instructed in the manual. Don't power on the device before verifying the connections.
6. Weatherproofness of enclosure is guaranteed only if the cover is in place glands adequately tightened. Damage due to accidental entry of water can be avoided if the instrument is installed in a rain shade.
7. If the ambient temperature is high, the instrument should not be installed to receive direct sunlight. In case such a position of shade is not available, a heat shield should be fitted above the instrument especially if the operating temperature lies between 60°C and 80°C.

9 Electrical Connections

Note: is compatible only with 24V DC power supply.

Note: does not have any keys to operate. The Fail-safe feature has been implemented in accordance with connection.

9.1 For Fail-safe High

If a device is mounted at top of the tank then follow the instructions given below for Electrical Connections:

9.2 For Standard Connector

- Connect positive terminal to Pin no. 3 of the device.
- Connect negative terminal to Pin no. 1 of the device.
- Connect fuse between positive terminal and Pin no. 3 of the device.
- Output can be taken between Pin no. 1 and 2.

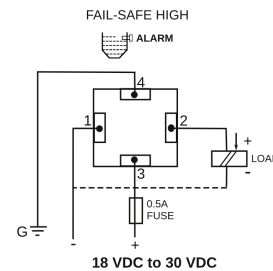

Figure 5: Fail-safe High

9.3 For M-12 Connector

- Connect positive terminal to Pin no. 1 of the device.
- Connect negative terminal to Pin no. 3 of the device.
- Output can be taken from Pin no. 4.

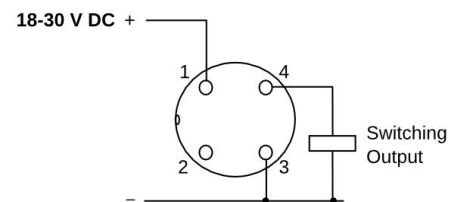

Figure 6: M-12 Connector Connection for Fail-safe High

9.4 For Fail-safe Low

If a device is mounted at bottom of the tank then follow the instructions given below for Electrical Connections:

9.5 For Standard Connector

- Connect positive terminal to Pin no. 2 of the device.
- Connect negative terminal to Pin no. 1 of the device.
- Connect fuse between positive terminal and Pin no. 2 of the device.

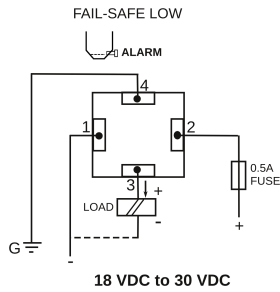

Figure 7: Fail-safe Low

- Output can be taken between Pin no. 1 and 3.

9.6 For M-12 Connector

- Connect positive terminal to Pin no. 4 of the device.
- Connect negative terminal to Pin no. 3 of the device.
- Output can be taken from Pin no. 1.

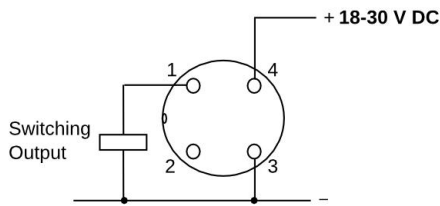

Figure 8: M-12 Connector Connections for Fail-safe Low

10 Output Check Test

Hold the magnet at the target place of the instrument, the current status of the switching LED and the PNP output will change and when the magnet is released from the target area the status of the switching LED and PNP output is switched to there previous (original) state.

10.1 Output Indications

Green LED Glows When:

- Fork is Uncovered and Fail-safe is High
- Fork is Covered and Fail-safe is Low

Red LED Glows When:

- Fork is Covered and Fail-safe is High
- Fork is Uncovered and Fail-safe is Low

11 Sensitivity

Note: Set the sensitivity value between 1-5.

Sensitivity of the tuning fork may have to be adjusted depending on the density of material of the application media. Vital-T has a LED display which helps in visualizing the desired sensitivity level. The device ships with a default sensitivity level .

- Magnetic key held at the target area of instrument the current status of the PNP and Led output will change and blue Led light flash two times, then released the key.
- Again the same process will be proceed Hold magnetic key at the target area of instrument and the current status of the PNP and LED output will change and blue led light blink two times then released the magnetic key and led light will be consent.
- Enable for sensitivity process firstly, hold magnetic key at the taget area of instrument at the 1 time and sensitivity set 1. Same process will be proceed for set the sensitivity.

Select the sensitivity value with the help of Table 3 5.

Number of Times Led Blink	Sensitivity
1	1
2	2
3	3
4	4
5	5

Table 5: Sensitivity

12 Error Indications

LED ERROR INDICATION	DESCRIPTION	TROUBLESHOOTING
All LEDs OFF	Low Voltage (Below 10V)	Increase Voltage
Blue LED Blinks (1 Second)	It is because of Serial Communication	Stop Serial Communication
Red LED Blinks Continuously	Oscillator Failed/Fork is not connected	
Blue LED Blinks Slowly (1 Second)	Temperature goes above 100°C	
Blue LED Blinks Fast (300 MiliSeconds)	Temperature goes above 110°C	
Blue LED Glows Permanently	Temperature goes above 120°C	

Table 6: Error Indications

Troubleshooting: The following reasons may be responsible for the absence of vibrations in the fork:

- The instrument is damaged.
- Heavy build-up of application medium can dampen the fork oscillations. In this case, the fork requires to be cleaned.
- If material is very viscous, the fork vibrations will resume when the fork is uncovered. **In this case, the error indication should be ignored.**

13 Customer Support

Thank you for going through the instructions given in this manual. To further ease the process of installation and use, we have developed special demo videos which are hosted on YouTube.

Sapcon's YouTube channel, SAPCON INSTRUMENTS, lists all these videos: <https://goo.gl/dnxfcz>

Should you require further information regarding installation, use or working of the instrument, please don't hesitate to contact us. Kindly provide the following information at the time of contacting:

- Instrument Model and Serial Number
- Purchase Order Number and Date of Purchase
- Description of the query
- Your contact details

In an attempt to serve you better, we are open seven days a week (9:30am to 7:30pm). We are available at:

- www.sapconinstruments.com
- sales@sapcon.in
- +91-731-4757575

14 Order Code

Product

VT: Vital-T: compact tubular vibrating fork type level limit switch appropriate for all types of solid , granules and powders

Type

I : Integral (sensor in same unit)

Probe Housing Material

PHS6 : SS 316

Probe Housing Cable Entry

PCPG11 : Threaded, PG 11 cable gland, Polyamide

Output

PNP : PNP (Voltage upto 18 to 30V DC)

Power Supply

DC3 : 18 to 30V DC

Mounting

MB10S6 : Threaded, G 1" (BSP), SS 316

MN10S6 : Threaded, NPT 1", SS 316

Vibrating Fork

VF110 : Fluido Fork, 110 mm, Tines 100 mm, SS 316

Finish

HB : Standard

Operating Temperature

15T : Upto 150°C

Probe Length

1.26H : 126 mm

Example -

VT-I-PHS6-PCPG11-PNP-DC3-MB10S6-VF110-HB-15T-1.26H