



Grown...to meet challenges

INSTRUCTION MANUAL

SLW

Conductivity Level Limit Switch

Version 2.1

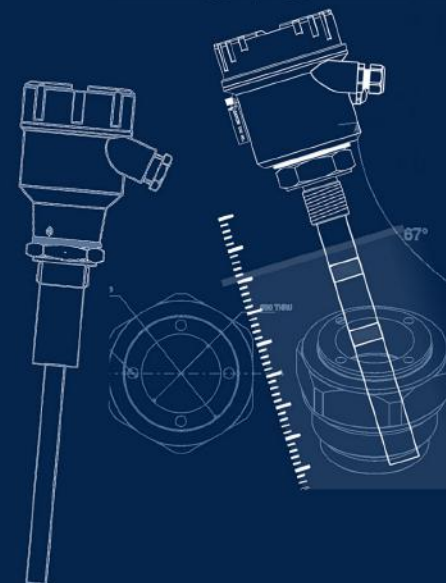
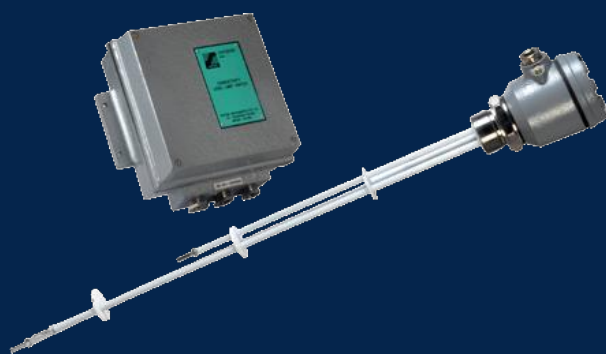

SAPCON INSTRUMENTS PVT. LTD.

30+ Years in Process Control Instrumentation

An ISO 22000 company

www.sapconinstruments.com

Contents

Revision History	4
1 Introduction	5
2 Operating Principle	5
3 Measuring System	5
4 System Description	5
5 Technical Specifications	6
5.1 Evaluation Unit (Standard)	6
5.2 Probe	6
6 Installation	7
6.1 Probe	7
6.2 Evaluation unit	7
7 Connections	7
7.1 For Metallic Containers	7
7.2 For Electrically Insulated Vessels	7
8 Calibration	7
8.1 Single Point Operation	8
8.1.1 For Failsafe High	8
8.1.2 For Failsafe Low	8
8.2 Two point level limit switching with pump control logic	8
8.2.1 For Failsafe High	8
8.2.2 For Failsafe Low	8
9 Fail-Safe Operation	8
10 Switching Delay	9
11 Customer Support	9

List of Figures

1 SLW	5
2 Part Diagram	5
3 System Diagram	5

List of Tables

1	Evaluation Unit	6
2	Probe	6
3	Failsafe High	8
4	Failsafe Low	8
5	Failsafe High	8
6	Failsafe Low	9

Revision History

Revision	Date	Author(s)	Description
1.0	20 Mar 2014	RND	First Version Editing
1.1	10 Sep 2014	MRK	Applications Revision
1.2	26 Jun 2015	RND	Features Revision
1.3	29 Dec 2015	RND	Specs Revision
1.4	19 Jul 2016	RND	Specs Revision
2.0	08 Jan 2017	BRND	Revised Format
2.1	17 Sep 2017	BRND	Branding Revisions

1

1

- **Copyright:** All content on this document, such as text, graphics, logos and images is the property of Sapcon Instruments Pvt. Ltd. The selection, arrangement and presentation of all materials on this document and the overall design of this document is the exclusive property of Sapcon Instruments Pvt. Ltd.
- The images shown in this manual may differ from the actual instrument / housing in terms of dimensions, color and design. Please refer to GA drawings for dimensional details.
- Values (of performance) described in this manual were obtained under ideal testing conditions. Hence, they may differ under industrial environment and settings.

General Instructions

- Instrument shouldn't block the material filling inlet.
- Secure the cover of housing tightly. Tighten the cable glands. For side mounting, the cable glands should point downwards.
- For side mounting, provide a baffle to prevent the material from falling on the probe.
- When handling forks, do not lift them using their tines. While using them with solids, ensure that material size is less than 10mm.
- Deforming the shape of the tines may interfere with the fork's operating frequency.
- Make all electrical connections as instructed in the manual. Don't power on the device before verifying the connections.

1 Introduction

LEVTESTER SLW series of instruments can be used for level limit switching applications for single/two point action for conductive liquids. They can be used for :-

- A. Switching 'OFF' pumps when the tanks are full, thereby avoiding spilling and avoid wear and tear.
- B. For indicating empty tank in good time to avoid production stoppages.
- C. For maintaining a constant level to avoid material wastage.

They incorporate solid state circuits for better reliabil-



Figure 1: SLW

ity. Low voltage on probes provides operational safety. AC on probes prevents electrolytic deterioration of electrodes. Wide probe choice is available for aggressive materials, high pressures and high and low temperature operation. The instrument is easy to install and long cable connection is permissible between probe and evaluation unit.

2 Operating Principle

A low AC voltage is applied between the probe electrode and tank wall (or reference electrode in the case of insulated tanks). When the liquid comes in contact with the electrode tip, a conductive path is established between the electrode and the tank wall (or reference electrodes). A current, therefore flows between the two through the liquid. This current is sensed, amplified and made to operate a relay, whose contact in turn can be used for annunciation/control.

3 Measuring System

It comprises of a sensing probe and an evaluation unit. Single point control application needs one probe for a metallic container whereas an additional probe that serves the probe that serves the purpose of a ground electrode is necessary for insulated containers. For two point action two probes are necessary. One for High level and other for Low level.

4 System Description

Level sensing is done by partly insulated rod or probes as per application demand. Rod probes are suitable for short lengths of a max. 2 meters whereas wire rope

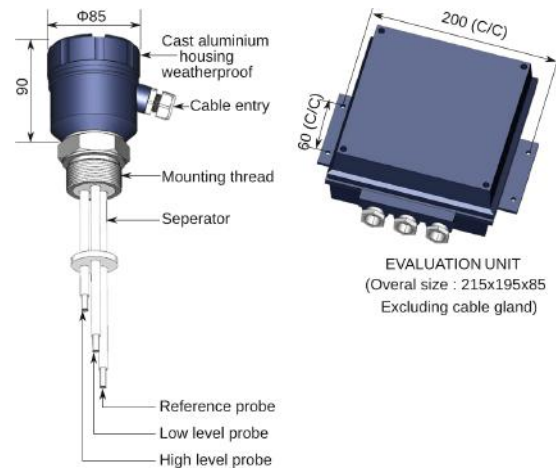

Figure 2: Part Diagram

are suitable for longer lengths. The sensing terminals are housed in a weather proof cast aluminium housing provided with a 1" BSP cable entry gland and a 1/2" BSP screwed connection. The probe electrodes are connected the evaluation unit via two core cable.

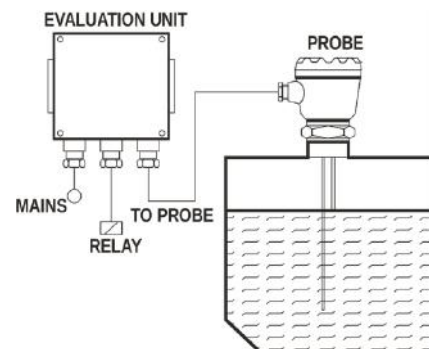

Figure 3: System Diagram

The evaluation unit comprises of power supply, amplifier, and a relay, housed in a cast aluminium weatherproof housing suitable for wall/back panel mounting. The cast aluminium housing is provided with three nos. of 1/2" BSP cable entries for wiring. The electrode is assembled on a glass epoxy printed circuit board duly lacquered for resisting moisture and fungus. One set of potential free change over contacts are available at the instrument terminals for annunciation/control.

5 Technical Specifications

5.1 Evaluation Unit (Standard)

For Evaluation Unit, please refer Table 1

PARAMETER	VALUE
Housing	Cast aluminium weatherproof stoving enamel painted suitable for wall/back panel mounting.
Protection	IP-65.
Ambient Temperature Range	-20 deg.C. to +60 deg. C.
Power Consumption	V A (approx)
Mains Voltage	V / 110 V AC, 50 Hz (+10% -15%)
Output	Three set point of potential free change-over contacts per channel rated at 5 Amps, 230 V AC for non-inductive loads.
Indication	<ul style="list-style-type: none"> ● Red LED for Alarm ● Green LED for Normal
Maximum Sensitivity	Kohms (20 micro mhos)
Operating Mode (Options)	<ul style="list-style-type: none"> ● Three independent switch points ● Three independent switch points with continuously settable time delay for probe covered and uncovered, selectable. ● Three switch points with pump control logic for each of the two channels. ● One independent switch point with or without continuously settable time delay for probe covered and/or uncovered condition and one pump control logic for the remaining channel
Fail Safe Feature	Fail safe High/Low field selectable for each channel
Weight	.25 Kgs (approx.)
Overall Dimensions	L = 180 mm, W = 180 mm, H = 85 mm

Table 1: Evaluation Unit

5.2 Probe

For Probe, please refer Table 2

PARAMETER	VALUE
Voltage	V AC (across probe and tank wall)
Current	mA maximum (between probe and tank wall through liquid)
Maximum Operating Temperature	deg. C. (standard version), deg. C. (special version)
Mounting	Screwed : 1/2" BSP / 1" BSP / 1-1/2" BSP Flanged : As per requirement

Table 2: Probe

6 Installation

6.1 Probe

The mechanical construction of the probe differs from application to application. Standard methods of mounting are screwed or flanged. A 1-1/2" BSP Mounting Bush (standard) is provided for screwing on to the container having a threaded flange fitted with the probe has to be bolted on to matching flanged welded to a pipe which in turn is fixed to the container. The construction and size of the mounting bush/flange as well as material of mounting bush/flange depends on the application. Depending on the application rod, probes can be either mounted from the top of the container or from the side of the container. Rope probes have to be mounted from the top only. For installing rod probes from the top of the containers, sufficient clearance between the roof and tank top is necessary as the probe has to be hoisted-up over the tank top during installation. Accurate length adjustments can be made at site for part insulated rod or rope probes.

6.2 Evaluation unit

The Evaluation Unit is suitable for back panel mounting. Refer mounting details diagram for hole locations in the back panel and drill holes accordingly. Remove instrument cover by unscrewing the four screws provided on front cover. Box fixing holes will be clearly visible on the box bottom, above and below card. Mounting hardware consisting of 4 nos. of M 4 cheese head screws have rubber 'O' rings to render the box dust tight after fitting. After installation the cover should be refitted to avoid dust ingress. The housing is suitable for outdoor installation. However, in no case should the instrument be subjected to temperature exceeding 60°C. Through the instrument can be installed outdoors, it should never be subjected to direct sun rays. Preferably a sun shade should be provided.

7 Connections

Refer to the connection diagram (enclosed herewith) as also to the one stuck on the inside cover of the evaluation unit. Connect appropriate supply 230 V/110V 50 Hz to terminals 1 and 2 (Line - L and neutral - N). Connect supply to the ground.

7.1 For Metallic Containers

- Single point operation :- Connect probe rod to terminals 13 (max.), and probe housing to 12 (com), ground terminal is provided on the housing for the purpose.
- Three point operation :- Connect high level probe to terminal 14 (max), probe housing to 13 (com), low

level probe to 15 (min) and very low level probe to 16 (min).

7.2 For Electrically Insulated Vessels

- Single point operation :- Same as in A.(1.) but connect the grounding probe electrode to terminal 12 (com).
- Three point operation :- Same as in A. (2.) but connect the grounding probe electrode to terminal 13 (com).

8 Calibration

After installing probes and making connections as mentioned above check for continuity between container and wall probe housing (for metallic containers). This should show low resistance. If possible, vary the liquid level in the vicinity of the set point and observe the LED indicators and relay switchings.

8.1 Single Point Operation

8.1.1 For Failsafe High

MATERIAL IN CONTAINER (ALARM)	HIGH LEVEL PROBE	RELAY	INDICATOR	
			Green	Red
Rising	Not Covered	Energized	ON	OFF
Rising	Covered	De-energized	OFF	ON
Falling	Covered	De-energized	OFF	ON
Falling	Not Covered	Energized	ON	OFF

Table 3: Failsafe High

8.1.2 For Failsafe Low

MATERIAL IN CONTAINER (ALARM)	HIGH LEVEL PROBE	RELAY	INDICATOR	
			Green	Red
Rising	Not Covered	De-Energized	OFF	ON
Rising	Covered	Energized	ON	OFF
Falling	Covered	Energized	ON	OFF
Falling	Not Covered	De-energized	OFF	ON

Table 4: Failsafe Low

8.2 Two point level limit switching with pump control logic

8.2.1 For Failsafe High

MATERIAL IN CON- TAINER (NORMAL)	HIGH LEVEL PROBE (ALARM)	LOW LEVEL PROBE	RELAY	INDICATOR	
				Green	Red
Rising	Not Covered	Not Covered	De-Energized	ON	OFF
Rising	Not Covered	Covered	De-energized	ON	OFF
Rising	Covered	Covered	Energized	OFF	ON
Falling	Not Covered	Covered	Energized	OFF	ON
Falling	Not Covered	Not Covered	De-energized	ON	OFF

Table 5: Failsafe High

8.2.2 For Failsafe Low

MATERIAL IN CONTAINER (NORMAL)	HIGH LEVEL PROBE (ALARM)	LOW LEVEL PROBE	RELAY	INDICATOR	
				Green	Red
Rising	Not Covered	Not Covered	Energized	OFF	ON
Rising	Not Covered	Covered	Energized	OFF	ON
Rising	Covered	Covered	De-energized	ON	OFF
Falling	Not Covered	Covered	De-energized	ON	OFF
Falling	Not Covered	Not Covered	Energized	OFF	ON

Table 6: Failsafe Low

N.B. : For two point logic the relay changes state when -

- Material level is rising and rises above the max. level probe.
- Material level is falling and falls below the min. level probe.

The aforesaid control action maintains the level in the tank between maximum and minimum level as set by the respective probe lengths. The switching differential obtained by the control action can also be used to reduce frequent switching of pumps due to ripples on the liquid surface and turbulence.

9 Fail-Safe Operation

Instrument operation is supposed to be fail safe if alarm condition is signaled by the relay in the de-energized condition. This necessitates a change in the state of the relay when the instrument is used for signaling either high or low alarm as the conditions are opposite. Selection switch is provided just for this purpose. It should be noted that the output contacts will change positions when the switch position is changed. Connections to external alarms should be made accordingly. Red and Green LED's on the PCB indicate alarm and normal operation. Red LED glows when the relay is in de-energized position.

10 Switching Delay

Incorporating a slight delay in switching, deliberately after the set level is reached gives a more stable operation. Provision is made in the Evaluation Unit to select the delay mode (i.e. either after probe is covered or uncovered) by means of switch. The delay is infinitely adjustable by means of a preset potentiometer within the limits of 0.5 to 20 seconds.

11 Customer Support

Thank you for going through the instructions given in this manual. To further ease the process of installation and use, we have developed special demo videos which are hosted on YouTube.

Sapcon's YouTube channel, SAPCON INSTRUMENTS, lists all these videos: <https://goo.gl/dnxfcz>

Should you require further information regarding installation, use or working of the instrument, please don't hesitate to contact us. Kindly provide the following information at the time of contacting:

- Instrument Model and Serial Number
- Purchase Order Number and Date of Purchase
- Description of the query
- Your contact details

In an attempt to serve you better, we are open seven days a week (9:30am to 7:30pm). We are available at:

- www.sapconinstruments.com
- sales@sapcon.in

- +91-731-4757575