



Grown...to meet challenges

# INSTRUCTION MANUAL

**SLC**

Capacitance Level Switch

Version 2.1

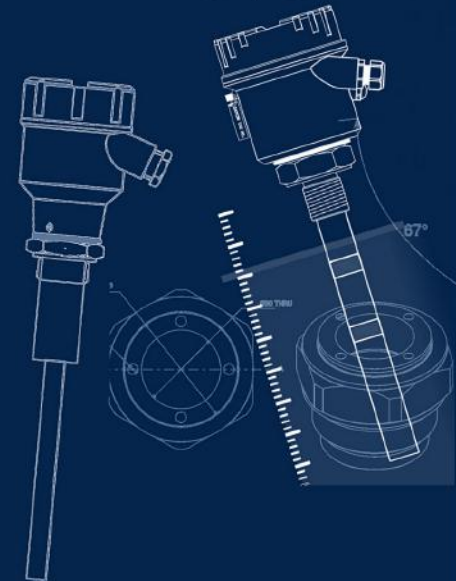

## SAPCON INSTRUMENTS PVT. LTD.

30+ Years in Process Control Instrumentation

An ISO 22000 company

[www.sapconinstruments.com](http://www.sapconinstruments.com)

Custom-built International Standard Products

80,000+ Successful Installations

Exporting to 90+ Countries

7500+ Clients

# Contents

- Revision History . . . . . 4
- 1 Safety Information . . . . . 5
- 2 Introduction . . . . . 5
- 3 Operating Principle . . . . . 5
- 4 Measuring System . . . . . 5
- 5 Features . . . . . 5
- 6 System Description . . . . . 5
- 7 Technical Specifications . . . . . 6
  - 7.1 Immuno Coat Probe . . . . . 6
  - 7.2 Evaluation Unit . . . . . 7
- 8 Installation Guidelines . . . . . 8
- 9 Inter Connection . . . . . 8
- 10 Precautions . . . . . 8
- 11 Fail-Safe Mode . . . . . 8
  - 11.1 Maximum Fail-Safe . . . . . 8
  - 11.2 Minimum Fail-Safe . . . . . 8
- 12 Calibration . . . . . 8
  - 12.1 For DOT display . . . . . 8
  - 12.2 For BAR display . . . . . 9
- 13 The Blind Calibration . . . . . 9
- 14 Troubleshooting . . . . . 10
- 15 Warranty . . . . . 10
- 16 Customer Support . . . . . 10

# List of Figures

- 1 SLC . . . . . 5
- 2 System Diagram . . . . . 6
- 3 Connection Diagram . . . . . 8
- 4 Connection Diagram . . . . . 9

# List of Tables

1	Immuno Coat Probe . . . . .	6
2	Evaluation Unit . . . . .	7
3	Sensitivity . . . . .	9
4	Troubleshooting . . . . .	10

## Revision History

Revision	Date	Author(s)	Description
1.0	25 Feb 2014	RND	First Version Editing
1.1	10 Aug 2014	MRK	Applications Revision
1.2	20 May 2015	RND	Features Revision
1.3	28 Nov 2015	RND	Specs Revision
1.4	12 Jun 2016	RND	Specs Revision
2.0	08 Jan 2017	BRND	Revised Format
2.1	17 Sep 2017	BRND	Branding Revisions

1

1

- **Copyright:** All content on this document, such as text, graphics, logos and images is the property of Sapcon Instruments Pvt. Ltd. The selection, arrangement and presentation of all materials on this document and the overall design of this document is the exclusive property of Sapcon Instruments Pvt. Ltd.
- The images shown in this manual may differ from the actual instrument / housing in terms of dimensions, color and design. Please refer to GA drawings for dimensional details.
- Values (of performance) described in this manual were obtained under ideal testing conditions. Hence, they may differ under industrial environment and settings.

### General Instructions

- Instrument shouldn't block the material filling inlet.
- Secure the cover of housing tightly. Tighten the cable glands. For side mounting, the cable glands should point downwards.
- For side mounting, provide a baffle to prevent the material from falling on the probe.
- When handling forks, do not lift them using their tines. While using them with solids, ensure that material size is less than 10mm.
- Deforming the shape of the tines may interfere with the fork's operating frequency.
- Make all electrical connections as instructed in the manual. Don't power on the device before verifying the connections.

## 1 Safety Information

- Before installing the RF-Capacitance (Coat-Shield) level controller, please read these instructions carefully and familiarize yourself fully with the requirement and functions of the instrument.
- Please do not dispose off the carton or packing material until the unit has been inspected in all respects. If the unit is received in damaged condition, kindly note the dispatch details and inform us immediately.
- Inter-connection must be done as per the national standards. If you find any difficulty or have any doubts about installing this product, please do not hesitate to contact our service center for instant support.

## 2 Introduction

RF-Capacitance (Coat-Shield) level limit switch utilizing specially designed Immuno coat probe offers a reliable solution to level detection problems so far difficult to solve with simple capacitance type system utilizing conventional probes. The main advantage offered by Coat Shield capacitance range of level switches is their ability to ignore build-up and coating of material on the probe. Purpose of adding a shield in between sensing element and ground is to avoid RF currents from reaching the container wall via the coating. Although there would be RF current flowing between the shield and the container wall via the build-up, it would not be considered by the measuring circuit and will not affect on the level measurement. This unique design enables the electronic circuitry to distinguish between significant process coating and the actual process material thereby gives reliable accurate switching.



Figure 1: SLC

Coat Shield Capacitance measurement using Immuno coat probe gives satisfactory solution in tough environments where,

- Material has a tendency to coat.
- There is bridging (build up) of material between probe and side wall.
- Material particles with electrostatic charge and varying temperature float in the vicinity of the probe.

## 3 Operating Principle

The sensing element and the container wall (or ground electrode) form a means to measure the capacitance of the system with and without the intervening material. When all the parameters that affect the capacitance value are kept constant then its value changes only due to the difference in material level. The sensed signal is further amplified and used to actuate the relay. The relay contacts are used for alarm or control purpose.

## 4 Measuring System

A complete measuring system comprises :

- Evaluation unit
- Immuno coat probe
- Inter-connecting cable

## 5 Features

- DC Power Supply 11-55 V DC.
- Compact size, easy to install.
- Customized mounting sizes like threading and Tri-clamp arrangement.
- Outputs options: PNP, open collector output.
- High temperature probe suitable up to 130 Deg C.
- Coating immunity, work even in conductive coatings.

## 6 System Description

Immuno coat probe is of a special construction with three concentrically positioned electrodes that are electrically insulated from each other. The innermost electrodes serve as the sense electrode whereas the one next to it is the shield, and the outermost is ground. The sense electrode is connected to a radio frequency source and the shield is also connected to the same source but through an isolating amplifier. They therefore have identical waveforms and the shield follows the sense, maintaining equivalent potential, frequency and phase relationship. Due to this there is no flow of RF current between the shield and the sense electrode. The flow of RF currents via the shield to side walls does not affect the measurement due to isolation amplifier.

The probe head is of cast aluminum weatherproof construction provided with suitable cable glands, and fitted on to the probe mounting arrangement. A discharge device is provided with the system where there is a possibility of generation of static charge in the service material. The Immuno coat probe is connected to the evaluation unit with a special screened cable of pre-trimmed length.

The Evaluation unit is housed in a cast aluminum weatherproof housing that is stoving enamel painted & provided with three nos. of cable entries of 1/2" size. The electronics and the inter-connecting terminals are assembled on a glass epoxy printed circuit board, that is heavily lacquered for rendering it immune to moisture, dust & fungus.

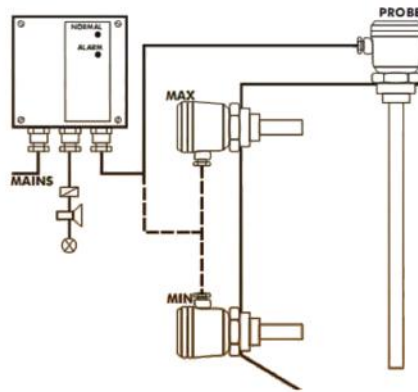

Figure 2: System Diagram

## 7 Technical Specifications

### 7.1 Immuno Coat Probe

For Immuno Coat Probe, please refer Table 1

PARAMETER	VALUE
Housing	Cast aluminum weather proof
Cable entry	One no.1/2 " BSP/NPT/BRASS/Plastic/ Stainless Steel
Cable gland	Single /double Compression
Mounting connection	<ul style="list-style-type: none"> <li>• Screw - 1"/1 1/2"/BSP/NPT</li> <li>• Flange - As per requirement / As per drawings</li> </ul>
Insulating material	PTFE/ Ceramic
Process Temperature	Probes types available for 80°C / 120°C/ 250°C/ 400°C/ 600°C
Extension	<ul style="list-style-type: none"> <li>• Rod - Stainless Steel/Mild Steel (Plated)</li> <li>• Rope - Galvanized Steel/Stainless Steel</li> </ul>
Sensing part	Stainless Steel/ Mild Steel (plated)
Grounding pipe	Galvanized steel/ Stainless Steel/Mild Steel (plated)
Stand-off	Galvanized steel/Stainless Steel/Aluminium Fin
Discharge device	In case of static charge build-up

Table 1: Immuno Coat Probe

## 7.2 Evaluation Unit

For Evaluation Unit, please refer Table 2

PARAMETER	VALUE
Housing	Cast Aluminum weather proof stoving enamel painted/Siemens Grey powder coated /Epoxy coated suitable for back panel/ wall mounting
Cable Entry	1/4" NPT DC Gland Brass
Cable Gland	Single/ Double compression Size 1/2"/ 3/4" BSP / NPT / Brass / Stainless steel / NG20
Tolerable Ambient Temp.	0°C to 60°C
Power consumption	5VA approx
Mains Supply	90 to 265 V AC, 50 Hz (universal power supply) , 110/230, 240 V AC 50 Hz Optional 24 VDC
Fail-Safe Mode	Max / Min field selectable
Output	One/two set of potential free c/o contacts rated at 6Amps 230 V AC for non inductive loads
Indication	Red LED for alarm and Green LED for Normal condition
Sensitivity Indicator	Ten dot display for sensitivity calibration, also for showing the material trend in the vicinity of the probe
Calibration	Through multi-turn potentiometer
Measuring Frequency	100 KHz
Response Time	Less than 1 second
Switching Delay	Adjustable from 5 to 20 seconds (covered and uncovered) applicable for model SLsC-322M and 622M
Inter-Connection	Between Probe and Evaluation unit, by special coaxial cable with drain wire
Weight	2.25 Kgs
Over all dimensions	As per approved Drawings

Table 2: Evaluation Unit

## 8 Installation Guidelines

- Instrument can be installed in almost any position.
- Install probe in such a way that sense, shield and non-active.
- Length must come in active zone.
- The threaded mounting connection should be as short as possible to avoid deposit of material in the nozzle cavity.
- When mounting is from side the cable entry should be pointing downwards, so that no moisture can enter.
- Make sure that the probe insulation is not damaged when inserting the probe through the nozzle.
- Probe should be installed away from the inlet. If it is not possible, fix baffle plate 300 mm above from the probe.

## 9 Inter Connection

- Refer the attached diagram before making the inter connection.
- One such diagram is also pasted inside the evaluation unit cover.
- Connect the mains supply as mentioned inside the cover.
- Verify line voltage before switching on the instrument.
- Inter-connection between probe and evaluation unit is made by means of special PTFE co-axial cable of pre-trimmed length.
- Ensure controller unit is earthed properly.
- Use three-core cable of 1.5 mm sq. diameters, in case of A.C power supply & relay contacts.

## 10 Precautions

- Refer the diagram pasted inside the cover before making the inter-connection.
- Do not immediately energize the instrument until wires are fully secured.
- In case of DC power supply instrument -ve is ground.
- Always tighten the housing cover and the cable entry securely.

## SLsC-122M/130

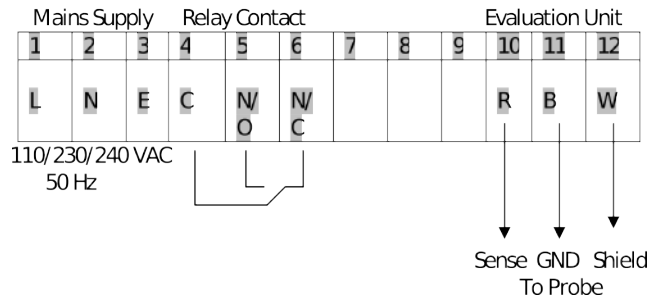

Figure 3: Connection Diagram

- Use appropriate size of spanner for rotating the mounting bush.
- True earths must be connected to the instrument.
- Use recommended cable only for interconnection.
- Weatherproofness of enclosure is guaranteed only, if the cover is in place & cable glands adequately tightened.

N.B: - Evaluation unit can be mounted away from the probe at a maximum distance of 15 meters in case of dot display instrument 30 meters in case of bar display instrument.

## 11 Fail-Safe Mode

This is field selectable option depending upon the process requirement. Maximum fail-safe or minimum fail-safe can be obtained by selecting the FSS toggle switch mounted in the center of the PCB. De-energized condition of the relay is used to initiate an alarm. Even if the mains supply fails or instrument doesn't work, relay will initiate an alarm.

### 11.1 Maximum Fail-Safe

When the level rises and the material covers the probe the relay is de-energized, an alarm is initiated and Red LED glows. For achieving this mode of operation shift the toggle switch to fail-safe high.

### 11.2 Minimum Fail-Safe

When the level falls and the probe is uncovered, the relay is de-energized, an alarm is initiated and Red LED glows. For achieving this mode of operation shift the toggle switch to fail-safe low.

## 12 Calibration

### 12.1 For DOT display

A DOT LED display serves as a sensitivity indicator. The indicator range is divided into ten parts. The divisions are as follows: The following standard procedure should be carried out when tank is Empty :

- Switch on the mains supply voltage.



DOT REGION	COLOUR	SENSITIVITY	REMARKS
1 to 6	Green	Low	
7 to 9	Yellow	Medium	
10	Red	High	Relay switching region

Table 3: Sensitivity

- Select the desired fail safe by using FSS toggle switch.
- For versions provided with adjustable time delay, turn the pot fully counter clockwise to the minimum delay condition.
- Now rotate the sensitivity adjustment potentiometer fully counter clockwise. In this condition dot display will be green.
- Fill the level up to the probe, so that it covers the probe tip sufficiently.
- Rotate the sensitivity potentiometer gradually clockwise observing the dot display to move through the green and yellow region to the Red region. Continue the turning of potentiometer until the relay just operates. This should occur close to the Red region.
- Without disturbing the sensitivity pot reduce the level of the material. As the probe gets uncovered the dot display will move from red through yellow to green. Record this display indication for future calibration.
- The calibration is now completed.
- If alarm condition does not change, then put DIP switch 1 to ON condition. If the RED LED alarm still glows then put DIP switch 1 to off condition and turn the DIP switch 2, 3 or 4 to ON condition till Green LED glows and note if SENS/DEV indicator shows any LED glowing.
- Rotate the SENS trimmer slowly towards clockwise direction till display is on. SENS/DEV indicator shows 4 LED's glowing.
- Fill the level up to the probe, so that it covers the probe tip sufficiently.
- If the RED alarm LED glows along with the relay change over, then the calibration is complete.
- If the Green LED still glows, then further rotate the SENS trimmer clockwise till the RED alarm LED glows.

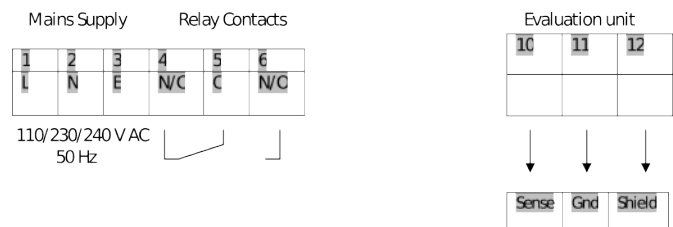

Figure 4: Connection Diagram

## 12.2 For BAR display

The following standard procedure should be carried out when tank is Empty :

- Switch on the mains supply voltage.
- Select the desired fail-safe by using FSS toggle switch.
- For versions provided with adjustable time delay, turn the pot fully counter-clockwise to the minimum delay condition.
- Ensure all the four DIP switches just below SENS trimmer are in off position.
- Note the display in SENS/DEV indicator.
- If all the Red LEDs are glowing along with the alarm Red LED, then turn the SENS trimmer slowly towards anti-clock wise.

## 13 The Blind Calibration

In case it is not possible to vary the material level during calibration the standard method cannot be used. In such cases an approximate calibration can be carried out by the blind method until a standard calibration is done. However it is not an accurate method and should only be used when standard method is not possible.

- Set the FSS to desired mode by means of the toggle switch.
- Ensure that the material does not cover the sense element.
- Rotate the sensitivity adjust pot fully counter-clockwise.

## 14 Troubleshooting

PROBLEM	PROBABLE CAUSE	REMEDY
No change in bar display	No change in the level or evaluation unit is faulty	Check level or evaluation unit with other probe
LED indication does not changes	LED driving circuit faulty	Diagnose the fault and remove the defective component
Relay not actuating but LED changes	Relay or its associated circuit is faulty	As above
Evaluating unit o.k. but no change occurs when probe is connected	Probe or inter connection wire is disconnected	Check cable connectivity and probe
Relay actuating but no output.	Relay contact worn out /track discontinuity	Replace relay/ check tracks

Table 4: Troubleshooting

## 15 Warranty

Instrument is manufactured as per the purchase order specification. Standard guarantee for twelve months from the date of commissioning or eighteen months from the date of supply which ever is earlier. Guarantee is against manufacturing defects. We undertake to correct such defects which are due to workmanship, at our expenses, Instrument should be forwarded to us on freight paid basis with seals unbroken. The guarantee is valid for our customer and does not extent to third parties or caused by mishandling, accident or abnormal conditions.

## 16 Customer Support

Thank you for going through the instructions given in this manual. To further ease the process of installation and use, we have developed special demo videos which are hosted on YouTube.

Sapcon's YouTube channel, SAPCON INSTRUMENTS, lists all these videos: <https://goo.gl/dnxfcz>

Should you require further information regarding installation, use or working of the instrument, please don't hesitate to contact us. Kindly provide the following information at the time of contacting:

- Instrument Model and Serial Number
- Purchase Order Number and Date of Purchase
- Description of the query
- Your contact details

In an attempt to serve you better, we are open seven days a week (9:30am to 7:30pm). We are available at:

- [www.sapconinstruments.com](http://www.sapconinstruments.com)
- [sales@sapcon.in](mailto:sales@sapcon.in)
- +91-731-4757575