



Grown...to meet challenges

INSTRUCTION MANUAL

SLA..M/B

Admittance Level Switch

Version 2.1

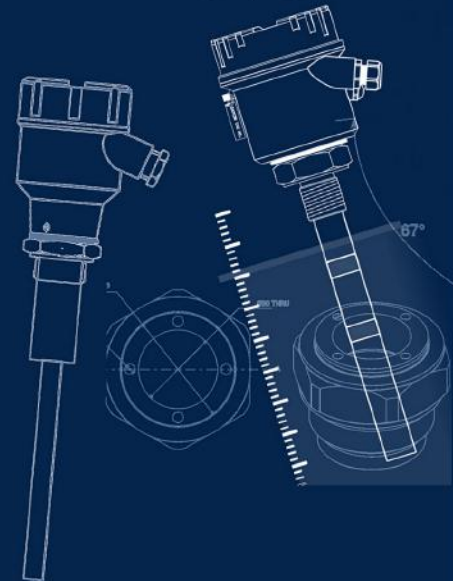

SAPCON INSTRUMENTS PVT. LTD.

30+ Years in Process Control Instrumentation

An ISO 22000 company

www.sapconinstruments.com

Contents

Revision History	4
1 Introduction	5
2 Operating Principle	5
3 System Description and Features	5
4 Application Note	5
5 Technical Specifications	6
5.1 Evaluation Unit	6
5.2 Probe	7
6 Installation Guidelines	8
7 Electrical Connections	8
8 Calibration	8
11 Safety Information and Maintenance	9
12 Recommended Spares	9
13 Warranty	9
14 Customer Support	10

List of Figures

1	SLA..M/B	5
2	Part Diagram	5
3	System Diagram	5
4	Connection Diagram	8
5	Dot Display Connection	8

List of Tables

1	Evaluation Unit	6
2	Probe	7
3	Troubleshooting	10

Revision History

Revision	Date	Author(s)	Description
1.0	12 Apr 2014	RND	First Version Editing
1.1	20 Oct 2014	MRK	Applications Revision
1.2	27 Jun 2015	RND	Features Revision
1.3	19 Dec 2015	RND	Specs Revision
1.4	23 Aug 2016	RND	Specs Revision
2.0	08 Jan 2017	BRND	Revised Format
2.1	17 Sep 2017	BRND	Branding Revisions

1

1

- **Copyright:** All content on this document, such as text, graphics, logos and images is the property of Sapcon Instruments Pvt. Ltd. The selection, arrangement and presentation of all materials on this document and the overall design of this document is the exclusive property of Sapcon Instruments Pvt. Ltd.
- The images shown in this manual may differ from the actual instrument / housing in terms of dimensions, color and design. Please refer to GA drawings for dimensional details.
- Values (of performance) described in this manual were obtained under ideal testing conditions. Hence, they may differ under industrial environment and settings.

General Instructions

- Instrument shouldn't block the material filling inlet.
- Secure the cover of housing tightly. Tighten the cable glands. For side mounting, the cable glands should point downwards.
- For side mounting, provide a baffle to prevent the material from falling on the probe.
- When handling forks, do not lift them using their tines. While using them with solids, ensure that material size is less than 10mm.
- Deforming the shape of the tines may interfere with the fork's operating frequency.
- Make all electrical connections as instructed in the manual. Don't power on the device before verifying the connections.

1 Introduction

Sapcon admittance level limit switch utilizing specially designed Immuno coat probe offers a reliable solution to level detection problems so far difficult to solve with capacitance type system utilizing conventional probes. The main advantage offered by admittance range of level switches is their ability to ignore build up and coating of material on the probe. Purpose of adding a shield in between sensing element and ground is to avoid RF currents from reaching the container wall via the coating. Although there would be RF current flowing between the shield and the container wall via the build-up, it would not be considered by the measuring circuit and will not affect on the level measurement. This unique design enables the electronic circuitry to distinguish between significant process coating and the actual process material thereby gives reliable accurate switching.



Figure 1: SLA..M/B

2 Operating Principle

The sensing element and the container wall (or ground electrode) form a means to measure the admittance of the system with and without the intervening material. When all the parameters that affect the admittance value are kept constant then its value changes only due to the difference in material level. The sensed signal is further amplified and used to actuate the relay. The relay contacts are used for alarm or control purpose.

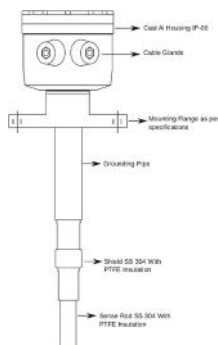

Figure 2: Part Diagram

3 System Description and Features

A complete measuring system comprises:

- Evaluation unit

- Immuno coat probe
- Interconnecting cable

Immuno coat probe is of a special construction with three concentrically positioned electrodes that are electrically insulated from each other. The innermost electrodes serve as the sense electrode whereas the one next to it is the shield, and the outermost is ground. The sense electrode is connected to a radio frequency source and the shield is also connected to the same source but through an isolating amplifier. They therefore have identical waveforms and the shield follows the sense, maintaining equivalent potential, frequency and phase relationship. Due to this there is no flow of RF current between the shield and the sense electrode. The flow of RF currents via the shield to side walls does not affect the measurement due to isolation amplifier.

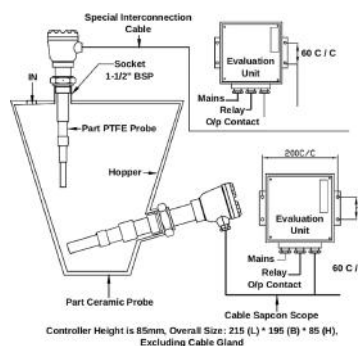

Figure 3: System Diagram

The probe head is of cast aluminium weatherproof construction provided with suitable cable glands, and fitted on to the probe mounting arrangement. A discharge device is provided with the system where there is a possibility of generation of static charge in the service material. The immuno coat probe is connected to the evaluation unit with a special screened cable of pre-trimmed length. The Evaluation unit is housed in a cast aluminum weatherproof housing that is stoving enamel painted & provided with three nos. of cable entries of 1/2" size. The electronics and the inter-connecting terminals are assembled on a glass epoxy printed circuit board that is heavily lacquered for rendering it immune to moisture, dust & fungus.

4 Application Note

Admittance measurement using Immunocoat probe gives satisfactory solution in tough environments where,

- Material has a tendency to coat.
- There is bridging (build-up) of material between probe and side wall.
- Material particles with electrostatic charge and varying temperature float in the vicinity of the probe.

5 Technical Specifications

5.1 Evaluation Unit

For Evaluation Unit, please refer Table 1

PARAMETER	VALUE
Housing	Cast aluminium weather proof stoving enamel painted/siemens Grey powder coated/Epoxy coated suitable for back panel/wall mounting.
Cable Entry	1/4"ET-2nos. and 1 no. for jack connector
Cable Gland	Single Double Compression, size 1/2"/3/4"BSP/ NPT/ Brass/ Stainless Steel/ NG20
Tolerable Ambient Temp.	0°C to 60°C
Power Consumption	5VA Approx.
Mains Supply	90 to 265 V AC,50Hz (Universal Power Supply), 110/230 V AC-50Hz Optional 24 V DC
Mounting	<ul style="list-style-type: none"> • Screwed - 1"/1-1/2" BSP/NPT (M) • Flanged - (As per your order) • Material - MS (Plated) / SS
Fail-Safe Mode	Max/Min field selectable
Output	One/Two set of potential free c/o contacts rated at 6A 230V AC for non-conductive loads
Indication	Red LED for alarm and Green LED for normal condition
Sensitive Indicator	Ten Dot display for sensitivity Calibration, also for showing the material trend in the vicinity of the probe
Calibration	Through multi-turn potentiometer
Measuring Frequency	100KHz
Response Time	Less than 1 second
Switching Delay	Adjustable from 5 to 20 seconds(covered and uncovered)applicable for model SLA322M and 622M
Inter-connection	Between Probe and Evaluation Unit, by special coaxial cable with drain wire
Weight	2.25kgs
Overall Dimensions	Please refer attached drawing 10 and 11

Table 1: Evaluation Unit

5.2 Probe

For Probe Specifications, please refer Table 2

PARAMETER	VALUE
Housing	Cast aluminium weather proof
Cable Entry	one no. 1/2" BSP/NTP/Brass/Stainless Steel
Cable Gland	Single/Double Compression
Mounting Connection	<ul style="list-style-type: none"> • Screw - 1"/1 1/2" BSP/NTP • Flange - As per requirement
Insulation	Part/Full
Insulating Material	PTFE/Ceramic
Process Temperature	Probes types available for 80°C/120°C/250°C/400°C/600°C
Extension	<ul style="list-style-type: none"> • Rod - Stainless Steel/Mild Steel (Plated) • Rope - Galvanized Steel/Stainless Steel
Sensing Part	Stainless Steel/Mild steel (Plated)
Grounding Pipe	Galvanized Steel/Stainless Steel/Mild Steel (Plated)
Stand-off	Galvanized Steel/Stainless Steel/Aluminium
Discharge Device	In case of static charge build-up

Table 2: Probe

6 Installation Guidelines

- Instrument can be installed in almost any position.
- Install probe in such a way that sense, shield non-active length must come in active zone.
- The threaded mounting connection should be as short as possible to avoid deposit of material in the nozzle cavity.
- When mounting is from side, the cable entry should be pointing downwards, so that no moisture can enter.
- Make sure that the probe insulation is not damaged when inserting through the nozzle.
- Probe should be installed away from the inlet. If it is not possible, fix baffle plate 300 mm above from the probe.
- Always refer the attached diagram before making the inter-connection.
- One such diagram is also pasted inside the evaluation cover.
- Connect the mains supply as mentioned inside the cover.
- Verify the line voltage before switching ON the instrument.
- Inter-connection between probe and evaluation unit is made by special PTFE coaxial cable of pre-trimmed length.
- Ensure control unit is earthed properly.
- Use three core cables of 1.5 sq mm diameters, in case of AC power supply relay contacts.

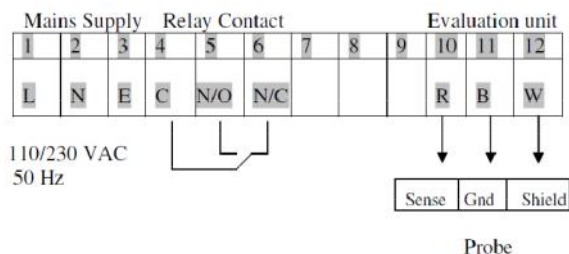

Figure 4: Connection Diagram

7 Electrical Connections

8 Calibration

For DOT Display Model SLA...M Series

A DOT DISPLAY model serves as a sensitivity indicator. The indicator range is divided into TEN parts. The

Following standard procedure should be carried out when tank is empty:

- Switch ON the mains voltage.
- Select the desired fail safe by using FSS toggle switch.
- For versions provided with adjustable time delay, turn the POT fully counter clockwise to the minimum delay condition.
- Now rotate the sensitivity adjustment POT fully counter clockwise. In this condition the DOT display will be GREEN.
- Fill the level up to the probe, so that it covers the probe tip sufficiently.
- Rotate the sensitivity POT gradually clockwise observing the DOT display move through the green and yellow region to the RED region. Continue the turning of potentiometer until the relay just operates. This should occur close to the RED region.
- Without disturbing the sensitivity POT reduce the level of material. As the probe gets uncovered the DOT display will move from RED through Yellow to Green. Record this display indication for future reference.
- The calibration is now completed.

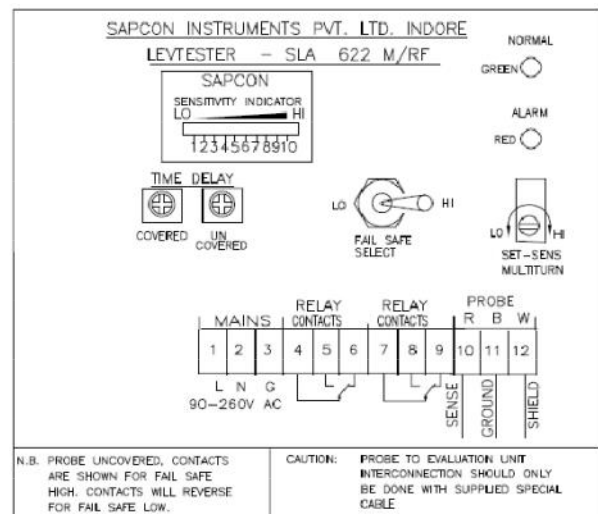

Figure 5: Dot Display Connection

For BAR Display SLA...B series

The following standard procedure should be carried out when tank is empty:

- Switch ON the mains power supply.
- Select the desired fail-safe by using FSS toggle switch.

- Refer the diagram pasted inside the cover before making the interconnection.
- Do not immediately energize the instrument until wires are fully secured.
- In case of DC power supply instrument -ve is ground.
- Always tighten the housing cover and the cable entry securely.
- Use appropriate size of spanner for rotating mounting bush.
- True earths must be connected to the instrument.
- Use recommended cable only for interconnection.
- Weatherproofness of enclosure is guaranteed only, if the cover is in place cable glands are adequately tightened.

11 Safety Information and Maintenance

Before installing the admittance level controller, please read these instructions carefully and familiarize yourself fully with the requirement and functions of the instrument. Please do not dispose off the carton or packing material until the unit has been inspected in all respects. If the unit is received in damaged condition, kindly note the dispatch details and inform us immediately. Inter-connection must be done as per the national standards. If you find any difficulty or have any doubts about installing this product, please do not hesitate to contact our service center for instant support. Please refer Table 3.

12 Recommended Spares

Instrument having no moving part therefore no wear and tear. However we advise to keep at least one set of card and probe assembly, if population of instrument are more.

13 Warranty

Instrument is manufactured as per the purchase order specification. Standard guarantee for twelve months from the date of commissioning or eighteen months from the date of supply whichever ever is earlier. Guarantee is against manufacturing defects. We undertake to correct such defects which are due to workmanship, at our expenses. Instrument should be forwarded to us on freight paid basis with seals unbroken. The guarantee is valid for our customer and does not extend to third parties or caused by mishandling, accident or abnormal conditions.

PROBLEM	PROBABLE CAUSE	REMEDY
No change in bar display	No change in level or evaluation unit is faulty	Check level or evaluation unit with other probe
LED indication does not changes	LED driving circuit faulty	Diagnose the fault and remove the defective component
Relay not actuating but LED changes	Relay and its associated circuit is faulty	As above
Evaluating unit o.k.but no change occurs when probe is connected	Probe or interconnected wire is disconnected	Check cable connectivity and probe
Relay actuating but no output	Relay Contact worn out/Track discontinuity	Replace relay/check tracks

Table 3: Troubleshooting

14 Customer Support

Thank you for going through the instructions given in this manual. To further ease the process of installation and use, we have developed special demo videos which are hosted on YouTube.

Sapcon's YouTube channel, SAPCON INSTRUMENTS, lists all these videos: <https://goo.gl/dnxfcz>

Should you require further information regarding installation, use or working of the instrument, please don't hesitate to contact us. Kindly provide the following information at the time of contacting:

- Instrument Model and Serial Number
- Purchase Order Number and Date of Purchase
- Description of the query
- Your contact details

In an attempt to serve you better, we are open seven days a week (9:30am to 7:30pm). We are available at:

- www.sapconinstruments.com
- sales@sapcon.in
- +91-731-4757575