



# SMART-SSI

## Continuous Speed Indicator

Comprehensive User's Manual

- . Introduction
- . General Description
- . Principle of Operation
- . Specifications
- . Connection Diagrams
- . Key, LED operation
- . Installation
- . Quick Calibration Chart
- . Quick Relay Configuration Chart

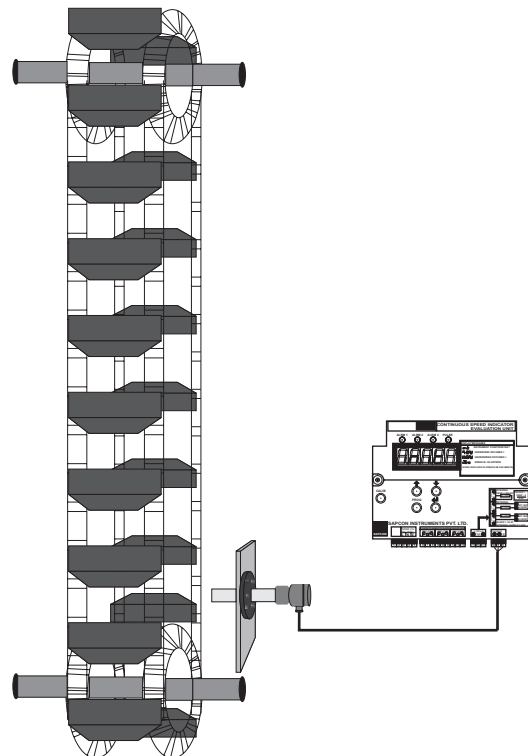

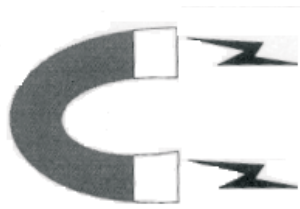

**CAUTION: This probe is highly magnetic. Keep it away from magnetosensitive materials such as computer discs and audio or video tapes.**

### Introduction:

SPEED-O-PILOT, MPSSI... is an intelligent and versatile speed limit switch suitable for detecting an underspeed condition of rotating, reciprocating or conveying equipment. It can also detect a missing object amongst a series of continuously moving objects moving at a constant speed, such as, a missing bucket in a bucket elevator, a missing object on a conveyor belt etc. It can be used to monitor speed of conveyors and bucket elevators. Special sensor detects moving ferrous objects from 100mm distance. High temperature models up to 200 deg. C are available. The salient features of the instrument are given below.

- Two underspeed / overspeed alarms, each with an independent relay.
- An independent relay for missing object/bucket detection.
- The display latches after detecting underspeed A condition. The display can be reset without opening the enclosure with the help of a magnetic key.
- Accurate pulse rate (speed) evaluation with optimum response.
- Easy to install. Flashing LED in the pre-amplifier indicates that the moving target is within the sensing range and facilitates target to detector distance setting.
- Easy to calibrate. The instrument can be calibrated prior to mounting, if the speed (buckets per minute) of the system is known. Programming is user friendly and menu driven, accomplished by 5 push button keys.
- 5 digit LED display indicates the speed in ppm (objects per min) and aids in programming.
- Built-in start-up delay programmable up to 99 sec with provision for interlocking with controlled equipment.
- Programmable set point and switching hysteresis.
- Rugged motion detector probe, especially designed for heavy industrial application. Works reliably in dusty environment.
- 4 LED indicators provided. Green LED indicates receipt of input pulses (when flashing) and 3 red LED's indicate underspeed-A alarm, underspeed-B and missing object alarm.
- Non-volatile memory stores the program parameters and calibration data indefinitely without the necessity of battery back up.

## Technical Specification:

### EVALUATION UNIT:

Alarm mode	underspeed, zero speed, missing object (field selectable)
Measuring range	20 to 9999ppm (pulse per minute)
Start-up time delay	programmable up to 99 sec
Programming via	4 push button keys
Indication	yellow LED for power-ON, red LED's for alarm, green LED for pulse detection
Relay output	3 relays, each with one set of potential free c.o. contact (rated at 6A, 230V,AC, 50Hz for non-inductive load), for underspeed, missing object & zero speed detection
Cable entries	3/4 nos.
Housing	cast aluminium, weatherproof, stoving enamel painted, suitable for back panel/wall mounting
Operating temp.	-20 to +60 deg. C
Power supply	90 to 265 VAC
Power consumption	5 VA approx.
Interlock	by potential free NO contact of contactor controlling the motor of the monitored equipment
Dimensions	overall 180X180X85 mm

### ELECTRONIC INSERT:

Housing	plastic with built-in terminals
Potting	epoxy compound
Operating temp.	-20 to +80 deg. C
Supply	15V DC at 15mA approx. derived from evaluation unit
Output	current pulses

### PROBE:

Probe head	cast Al weatherproof
Mounting	cast Al flange
Target range	adjustment by tri-clamp mechanism
Max. detection range	100mm
Target material	ferromagnetic
Min. target area	20X20 cm



## **PRINCIPLE OF OPERATION:**

The sensor works on the reluctance principle. Whenever the motion detector sensor detects a ferromagnetic target, a signal in the form of a pulse is given to the microprocessor (in the evaluation unit). The microprocessor evaluates the time between consecutive pulses & converts it into ppm. When the speed becomes lower than the programmed 'underspeed' value, underspeed relay changes state. Also, when no pulses are received for the programmed duration of time, zero speed relay changes state. When the system rotates at a constant speed, the time gap between two consecutive pulses remains constant. Now, if an object is missed (pulse is missed), this time gap increases. This is sensed by the microprocessor & it operates the missing object relay. The relay output contacts can in turn be used for signaling/controlling.

## **SYSTEM DESCRIPTION:**

### **MOTION DETECTOR PROBE (MDP):**

It operates on the reluctance principle. The MDP is designed for temperatures up to 150 deg. C standard (200 deg. C special) & has a large sensing range of 100mm. It has SS casing with an Al mounting flange and a tri-clamp arrangement for easy adjustment of target distance. The target should be made up of ferromagnetic material. An electromagnetic shield covers the rear of the probe to minimize interference from stray electromagnetic fields. It is especially designed for heavy industrial applications and works reliably in dusty environments.

### **ELECTRONIC INSERT:**

Electronic insert consists of an electronic circuitry enclosed in a plastic housing and potted with epoxy compound to render it immune to dust and moisture. It is housed in the cast Al probe head provided with a suitable cable gland, for running the cable. When MDP is suitably installed to sense the moving target, the electronic insert outputs pulses, whose frequency is proportional to the speed of the moving target. These pulses are transmitted to the evaluation unit.

### **EVALUATION UNIT:**

This consists SMP, That convert 90 to 265 VAC to regulated power supply, that not only provides power to the evaluation unit circuitry but also to the electronic insert in the probe housing. A microcontroller with its firmware processes the signal (transmitted by the PA) intelligently and displays the evaluated speed in ppm (objects/min). A 5 digit 7-segment LED display and its driver circuitry along with 5 push button keys form a user-friendly interactive interface. Various program parameters and calibration data are stored in a non-volatile memory indefinitely without the necessity of battery back up. The stored data can be edited whenever required via the user interface. Adequate cable entries are provided for wiring.



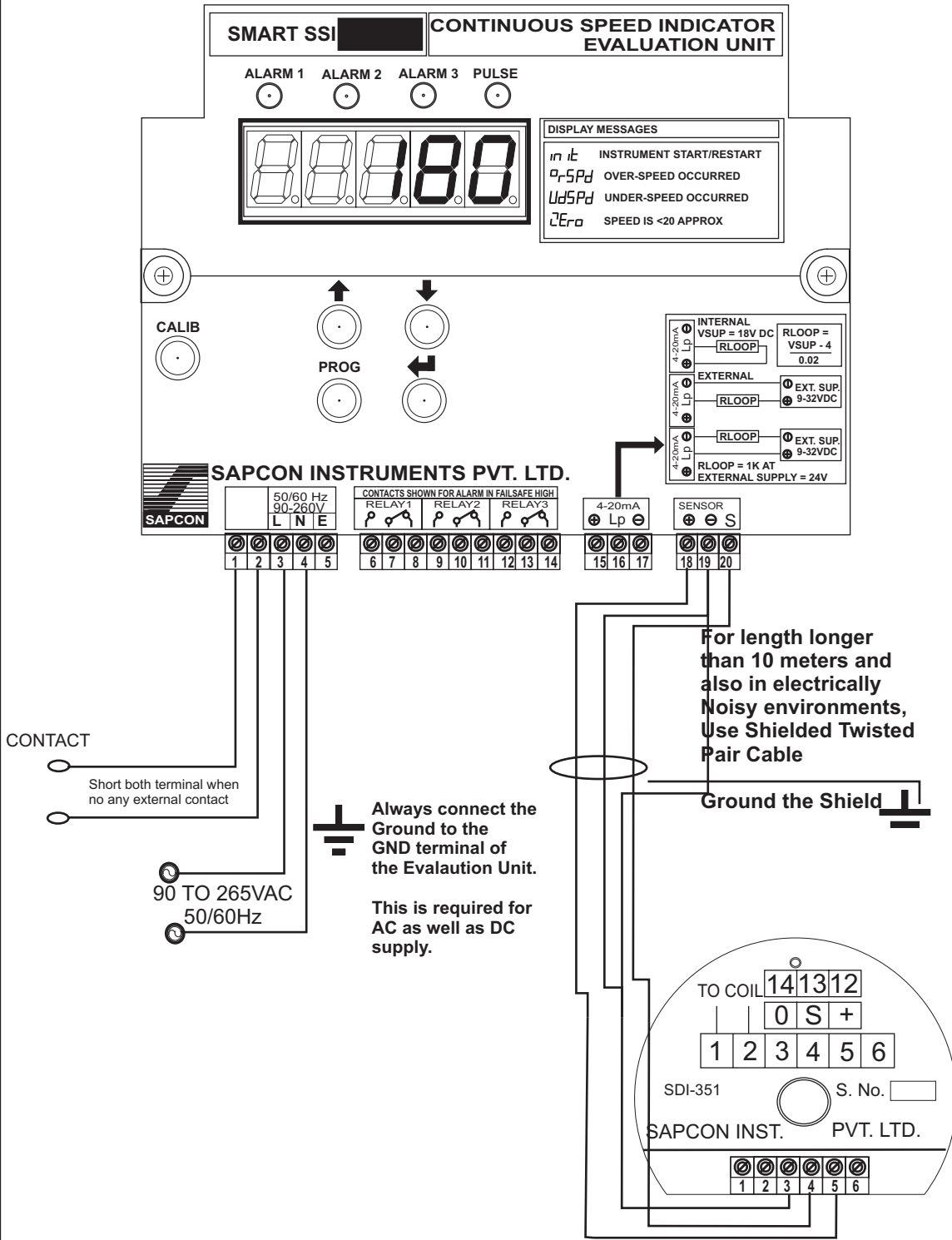

# Connection Diagram: 4-20mA Combinations

## Internal Isolated DC Power Supply:

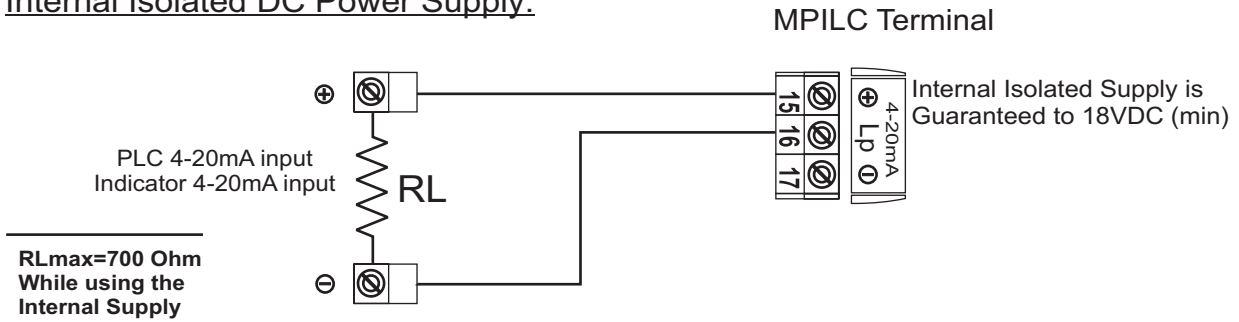

## External DC Power Supply (RL to Lp):

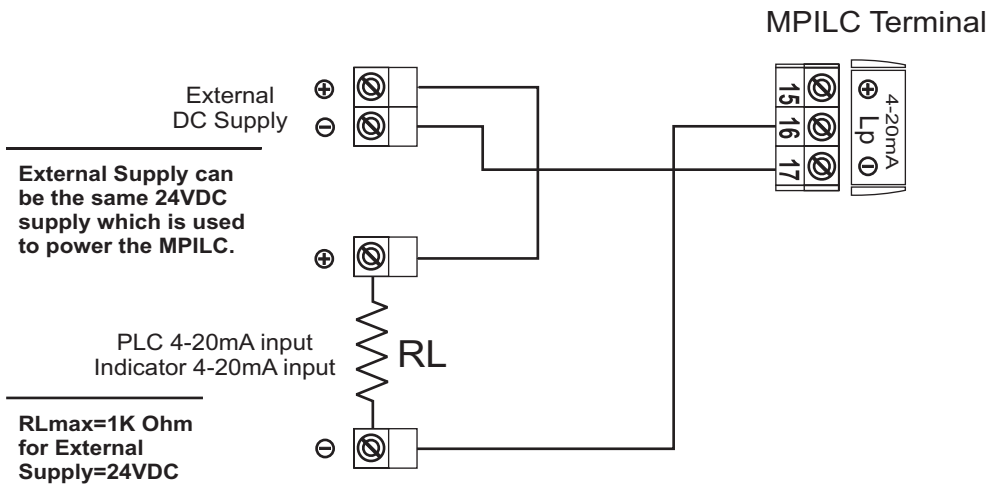

## External DC Power Supply (RL to Negative):

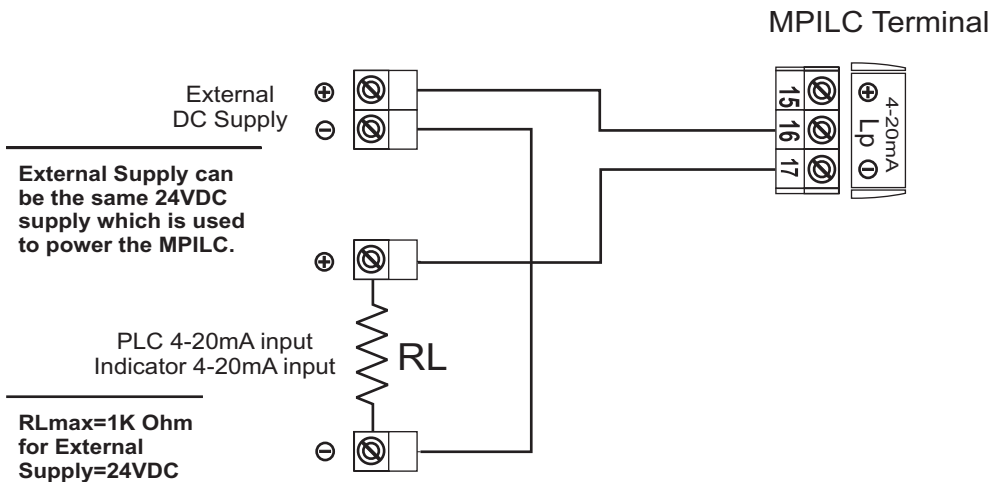

$$\text{Loop Resistance} = (\text{Loop Supply Voltage} - 4) \div 0.02 \text{ (Ohm)}$$

## KEYS USED & THEIR OPERATION:



Press and hold to enter in calibration menu till "CALB" not displayed. Press "ENTER" to change parameter or press "CALIB" key to exit from menu.



Press and hold to enter in relay setting till PROG not displayed. Press "ENTER" to change parameter or press "PROG" key to exit from menu.



Request to instrument for change parameter or apply displayed command press "ENTER" key.



To increment menu or data press "UP" key in programming mode.



To decrement menu or data press "DOWN" key in programming mode.

**Note: Changed parameter save only when "ENTER" apply after change.**

## LED & ALARM INDICATION:

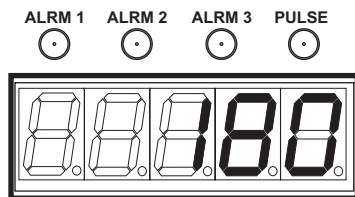

Alarm-1 LED associated with Relay-1.

Alarm-2 LED associated with Relay-2.

Alarm-3 LED associated with Relay-3.

Relay 1 & 2 program by user Relay -3 for missing object detection

**PULSE LED** indicate the pulse detect when bucket passing near sensor

Relay-3 latch when any bucket found missing it will be disable through magnetic key at given place.

### Fail Safe High or Maximum Fail Safe

#### Alarm Start:-

Displayed value < Low Set value - Low hysteresis &

Displayed value > High Set value - High hysteresis

#### Alarm Stop:-

Displayed value > Lower Set value

Displayed value < High Set value

### Fail Safe Low or Minimum Fail Safe

#### Alarm Start:-

Displayed value > Low Set value - Low hysteresis &

Displayed value < High Set value - High hysteresis

#### Alarm Stop:-

Displayed value < Lower Set value

Displayed value > High Set value

### During Alarm

Relay is at NC (Normally Connected)

Relay LED Glows (Red)

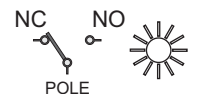

### During No Alarm

Relay is at NO (Normally Open)

Relay LED Turns Off

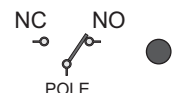



## INSTALLATION:

**MOTION DETECTOR PROBE:** Refer to the drawings for mounting details. The probe should be mounted, as close to the moving objects as is possible taking care that the moving objects do not strike the probe. When used on elevators it is preferable to mount the probe up at the driving wheel where the deflection of the chain is a minimum. The distance of the moving objects should not exceed the specified sensing range from the sensitive face of the probe. When the moving target is within the sensing range, a LED provided in the pre-amplifier starts flashing. Aluminium mounting flange and a tri-clamp arrangement, allow easy adjustment of target distance.

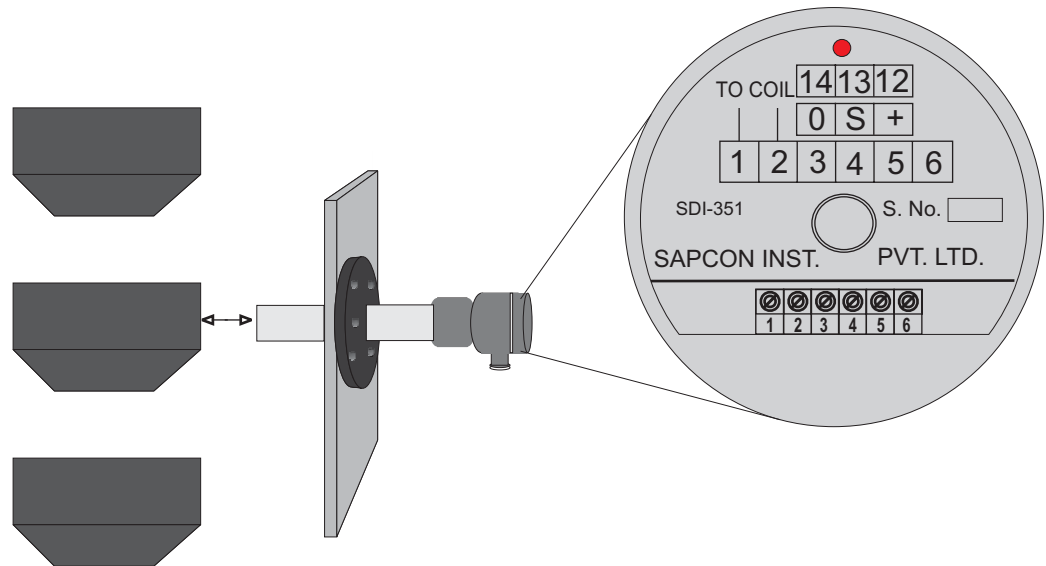

**ELECTRONIC INSERT:** For integral mounting, the electronic insert is already mounted in the probe head when shipped. It is fixed in the probe head by means of a single screw at the center of the electronic insert. For remote mounting, the electronic insert is mounted in a separate housing suitable for wall mounting when shipped. It is supplied with a PTFE screened cable of 1.5m length already connected to the electronic insert in a separate housing. The open end of the cable has to be connected with the terminals provided in the probe head. The remote housing should be installed as close to the probe as possible. The electronic insert in both types of installations should in no case be subjected to excessive heat due to hot environment or due to the direct impingement of sunrays. The temperature inside the electronic insert should not exceed 80 deg.C due to any reason.

**EVALUATION UNIT:** The evaluation unit is suitable for back panel or wall mounting. Refer to the mounting details diagram for hole locations in the back panel and drill holes accordingly. Remove instrument cover by unscrewing the four screws provided on front cover. Box fixing holes will be clearly visible on the box bottom, above and below card. Mounting hardware consists of 4 nos. of M4 cheese head screws with rubber 'O' rings, to render the box dust tight after fitting. After installation the cover should be re-fitted to avoid dust ingress. The housing is suitable for outdoor installation. However, in no case should the instrument be subjected to temperature exceeding 60 deg.C. Though the instrument can be installed outdoor, it should never be subjected to direct sunrays. Preferably a sunshade should be provided.

# START-UP DISPLAY:

Display "init" whenever instruments power on or restart. Startup time set on menu.

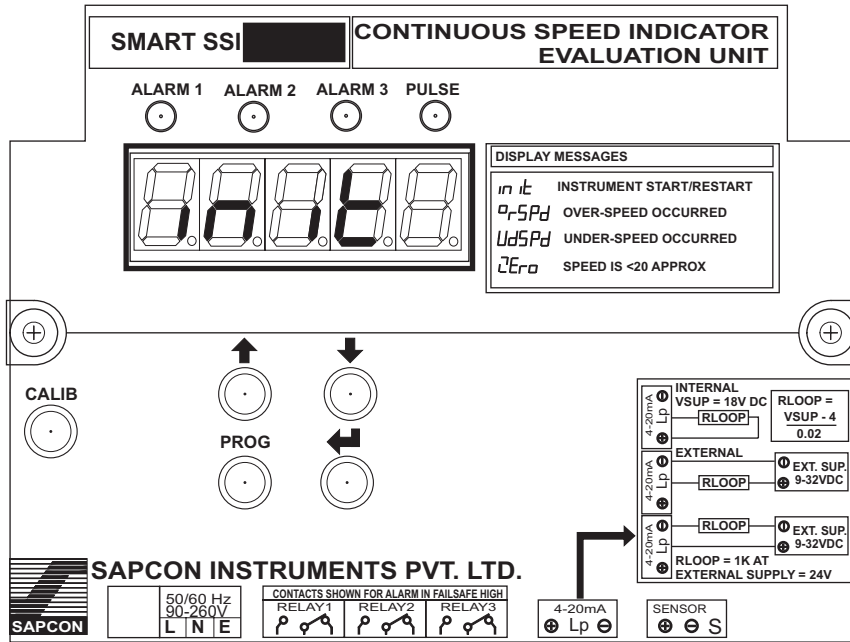

After startup its display current PPM (pulse per minute). Displayed value up to 9999.

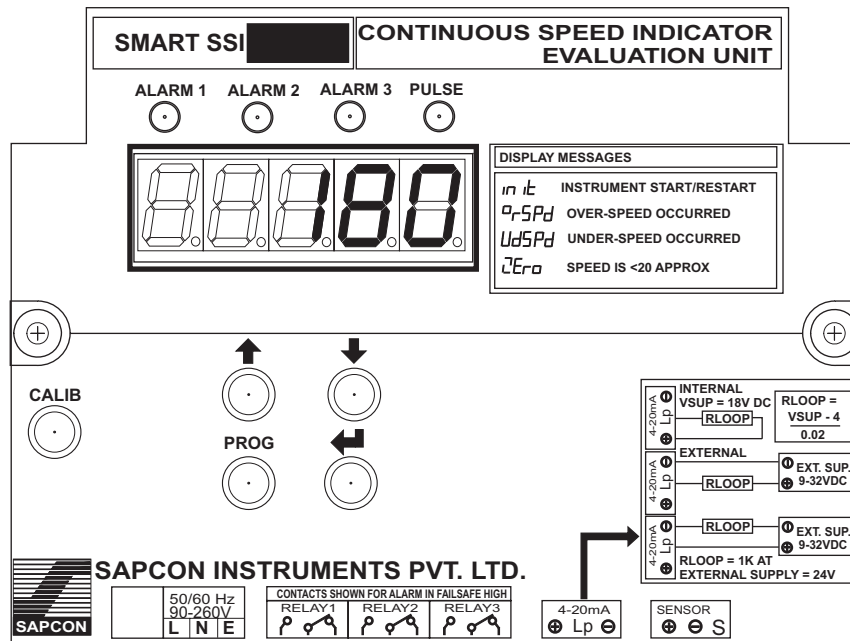

# CALIBRATION:

→ It is Offline calibration

→ For enter in MAIN menu press and hold

→ After displayed "calb" press enter key..



"CALIB" key till "calb" not displayed in screen..

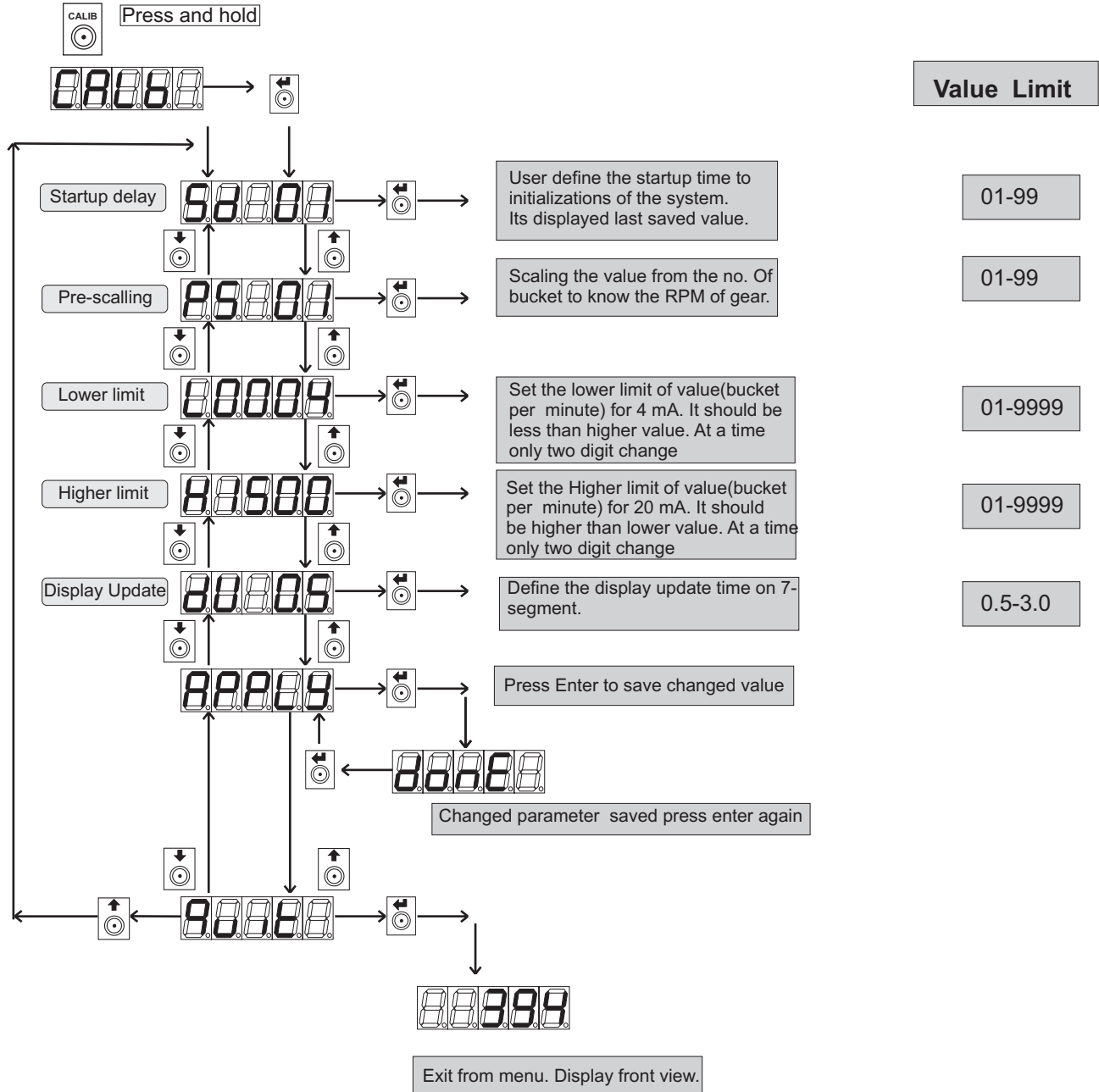

# RELAY PROGRAMMING:

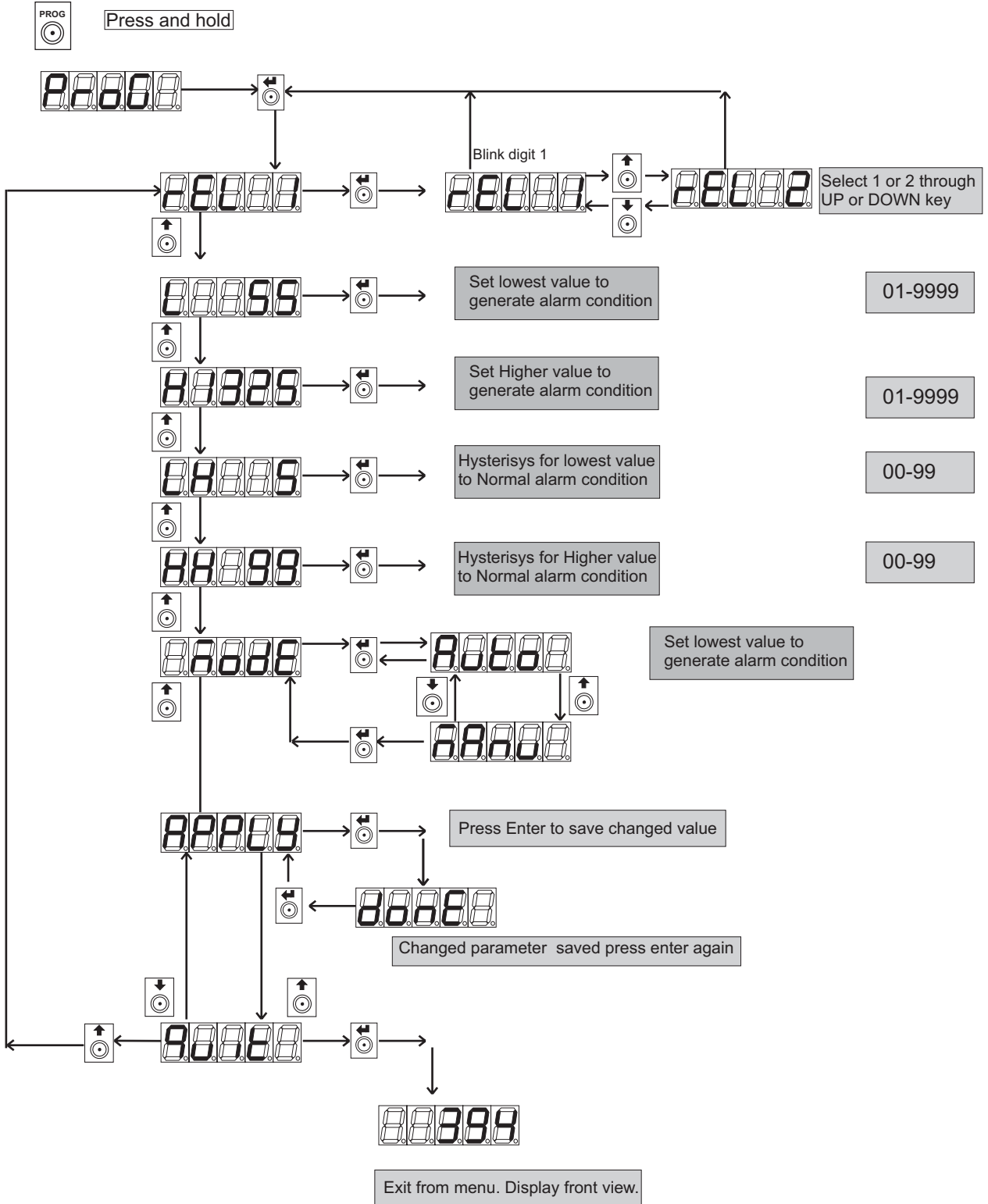

**Note:-** There is three independent relay. Relay 1 & 2 for user define lower and higher speed alarm indication  
Relay 1 & 2 is two point alarm condition.

ALARM condition:-

Displayed Value >Higher Value  
OR Displayed Value <Lower Value

Both condition generate Alarm for relay 1 & 2.

Normal Condition:-

For Auto mode:-

Displayed Value <Higher Value-Hysterisys  
And Displayed Value >Lower Value+Hysterisys

**For Manual Mode:- User reset Alarm manually through restart evaluation Unit or through magnet at given point.**

Alarm 3: Indicated by relay 3. Its indicate the missing object (bucket) between two consecutive bucket.

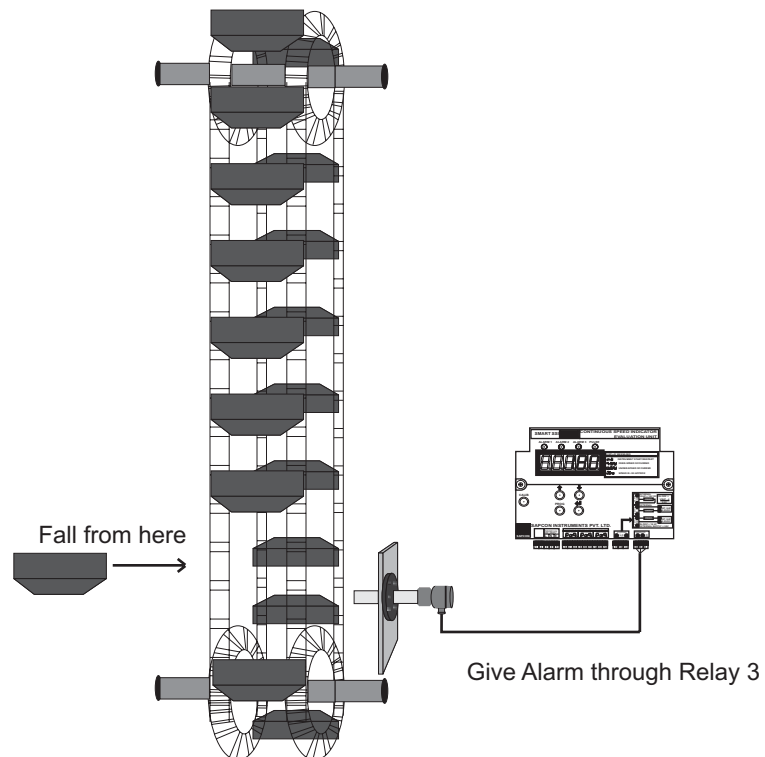

**Note:- Alarm 3 use very carefully.**

**INSTALLATION:**



**INSTALLATION:**

